

# Aerial Work Platforms

## Genie® Runabout™ Contractor

### Specifications

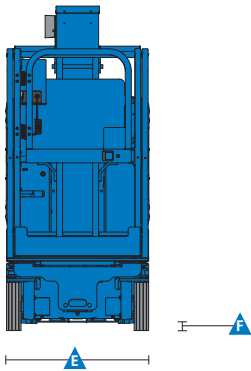
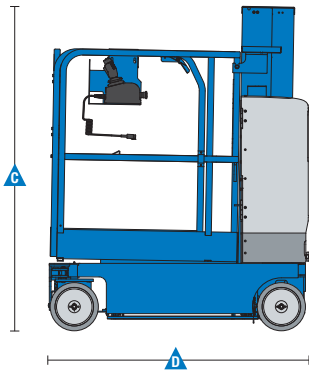
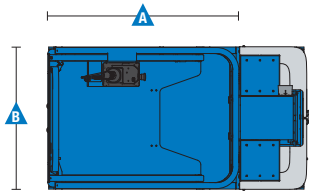

Models	GRC-12	
Measurements	US	Metric
Working height*	18 ft	5.66 m
Platform height	12 ft	3.66 m
<b>A B</b> Platform dimensions (length x width)		
Ext Platform dimensions - retracted	38 x 29.5 in	.97 x .75 m
Ext Platform dimensions - extended	55 x 29.5 in	1.4 x .75 m
<b>C</b> Height - stowed	67 in	1.70 m
<b>D</b> Length - stowed	4 ft 5.75 in	1.37 m
<b>E</b> Width ANSI, CSA	2 ft 5.5 in	.75 m
CE, AUS	2 ft 7.5 in	.80 m
<b>F</b> Ground clearance - center	2.5 in	.06 m

### Productivity

Lift capacity	500 lbs	227 kg
Lift capacity - extension deck	250 lbs	113 kg
Drive speed - stowed	2.5 mph	4.0 km/h
Drive speed - raised	0.5 mph	0.8 km/h
Gradeability**	30%	
Turning radius - inside	zero	zero
Turning radius - outside	4 ft 7 in	1.40 m
Raise / lower speed	12 / 16 sec	12 / 16 sec
Controls		24V DC proportional
Tires - solid non-marking	10 x 3 x 8 in	25 x 8 x 20 cm

### Power

Power source	24V (four 6V 225 Ah batteries)	
Hydraulic system capacity	2.2 gal	8.33 L

### Weight\*\*\*

ANSI, CSA	1,916 lbs	869 kg
CE, AUS	2,090 lbs	948 kg

### Standards Compliance

ANSI A92.6, CSA B354.2, CE Compliance, AS 1418.10

\* The metric equivalent of working height adds 2 m to platform height. U.S. adds 6 ft to platform height.

\*\* Gradeability applies to driving on slopes. See operator's manual for details regarding slope rating.

\*\*\* Weight will vary depending on options and/or country standards.

### Features

#### Standard Features

##### Measurements

###### GRC-12

- 18 ft (5.66 m) working height
- 12 ft (3.66 m) platform height
- Up to 500 lbs (227 kg) lift capacity

##### Productivity

- 2-person rated
- Steel platform and extension deck with swing gate
- Auxiliary platform lowering
- Low 15.5 in (.39 m) platform entry height
- Steel tube-in-tube mast system
- Compact base 29.5 x 53.75 in (.75 x 1.37 m)
- Ground clearance 2.5 inches (stowed)
- SmartLink™ control system
- Battery charge indicator
- On-board diagnostic system
- AC power to platform
- Work station trays
- Descent and tilt alarm
- Zero inside turning radius
- Dual wheel brakes
- Hydraulic brake release
- Pothole protection
- Hinged rear ABS covers for easy access to all major electrical and hydraulic components
- Tie down attachment points
- Overhead crane attachment point
- Large forklift pockets access
- Non-marking solid tires

##### Power

- Automatic 25 amp battery charger

#### Options & Accessories

##### Productivity

- Dual flashing beacons
- Motion alarm
- Fluorescent tube caddy
- Automotive horn
- EE Certification
- Biodegradable hydraulic oil
- Drive cutout while charging
- 10 ft retractable charging cord

##### Power

- 24V (four 6V 225 Ah batteries)
- 800 watt, 24V inverter (120-230V AC / 50-60 Hz)
- AGM maintenance-free batteries



#### Genie United States

18340 NE 76th Street  
P.O. Box 97030  
Redmond, Washington 98073-9730  
Telephone +1 (425) 881-1800  
Toll Free in USA/Canada +1 (800)-536-1800  
Fax +1 (425) 883-3475

#### Distributed By:

Effective Date: January, 2014. Product specifications and prices are subject to change without notice or obligation. The photographs and/or drawings in this document are for illustrative purposes only. Refer to the appropriate Operator's Manual for instructions on the proper use of this equipment. Failure to follow the appropriate Operator's Manual when using our equipment or to otherwise act irresponsibly may result in serious injury or death. The only warranty applicable to our equipment is the standard written warranty applicable to the particular product and sale and we make no other warranty, express or implied. Products and services listed may be trademarks, service marks or trade names of Terex Corporation and/or their subsidiaries in the USA and many other countries. Genie is a registered trademark of Terex South Dakota, Inc. © 2014 Terex Corporation.