

# Model 1932R SCISSOR LIFTS



## MORE ECONOMIC

- Lower Total Cost of Ownership

## MORE PRODUCTIVE

- Boost efficiency with optional AGM batteries
- Improved uptime

## MORE ACCESS

- Get into more places with compact dimensions and precise positioning ability for both drive and lift

## SMART DESIGN

- Improved reliable, simple active pothole protection
- Unparalleled component access
- All steel components like platform and service trays

## Standard Features

- Proportional Controls
- Battery Condition Indicator
- 220V-AC Receptacle in Platform
- All Motion Alarm
- 27 amp Multi-Function Universal Charger
- Horn
- Hourmeter
- Tilt Alarm and Light
- Lanyard Attach Points
- Movable, Removable Platform Control
- Nickel Plated Pins
- Lubrication Free Scissor Arm Bushings
- Scissor Maintenance Prop
- Active Pothole Protection System
- Lifting and Tie Down Points
- Fork Lift Pockets
- 36 in. (91 cm) Foot-Actuated Deck Extension
- Steel Swing-Out Doors
- Variable Tilt Window
- Manual Descent Cable
- Diamond Tread Steel Deck
- Greaseless Kingpin Joints
- Analyzer Port for Diagnostics
- Removable Ladder
- Self-Closing Gate

## Standard Specifications

- Batteries
- Charger
- Drive
- Hydraulic Reservoir Capacity
- Hydraulic Reservoir Pump
- Tire Size/Type (Non-Marking)
- Brakes
- 4 x 6V 220 amp-hr
- 27 amp High Frequency Charger
- Hydraulic Front-wheel
- 18 L
- Fixed Displacement Gear
- 323 x 100 mm
- Multi-Disc Friction



## Accessories & Options

- Flashing Amber Beacon
- 220 Amp-Hour AGM Batteries
- MDI (Ground)
- Anti-Vandalism Package for Ground Controls and Platform Controls
- Eagle Performance Charger
- 1,000W-AC Inverter
- Ambient Noise Alarm



# Model 1932R SCISSOR LIFTS

## Performance

• Working Height	7,80 m
A. Stowed height	2,10 m
B. Platform Height - Lowered	0,98 m
C. Platform Railing Height	1,11 m
D. Stowed Height (Rails Folded)	1,64 m
E. Platform Size Inside (W x L)	0,65 m x 1,57 m
F. Deck Extension	0,86 m
G. Overall Width	0,81 m
H. Overall Length <sup>2</sup>	1,74 m
I. Wheelbase	1,35 m
J. Ground Clearance (centre of machine)	7 cm
• Platform capacity – Indoor	 /230 kg
• Platform capacity – Outdoor	 /120 kg
• Lift/Lower Time ( no load )	24 / 29 sec.
• Maximum Drive Height	5,80 m
• Machine weight <sup>1</sup>	1.565 kg
• Maximum Ground Bearing Pressure	8,40 kg/cm <sup>2</sup>
• Drive Speed - Lowered	3,22 km/h
• Drive Speed - Elevated	0,80 km/h
• Gradeability	25%
• Turning Radius - Inside	0,0 m
• Turning Radius - Outside	1,69 m
• Tyres (Non-Marking Solid)	323 x 100
• Brakes	Hydraulic
• Drive (Nominal)	Hydraulic
• Batteries	4x 6V 220A/hr
• Charger (120/240V -50/60Hz)	24v @27Amp Automatic
• Pump Motor	4.5kW
• Hydraulic System	18L



<sup>1</sup> Certain options or country standards may increase weight and/or dimensions.  
<sup>2</sup> Includes ladder, excluding ladder 1,67 m

## Dimensions

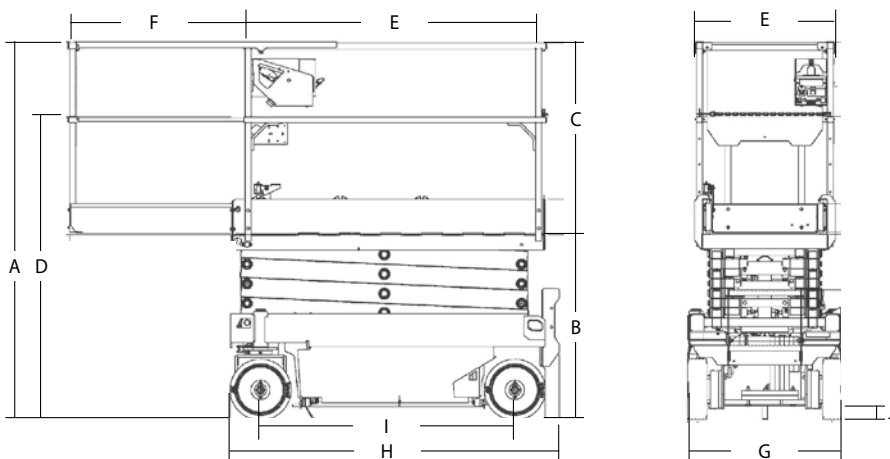

## IMPORTANT

JLG is continually researching and developing products and reserves the right to make modifications without prior notice. All data in this document is indicative. Certain options or country standards will increase weight. Specifications may change to meet country standards or with the addition of optional equipment.

Due to continuous product improvements, JLG Industries reserves the right to make specification and/or equipment changes without prior notification.

# JLG®

## JLG EMEA BV

Polaris Avenue 63  
 2132 JH Hoofddorp  
 The Netherlands  
 Phone: +31 (0)23 565 5665  
[www.jlg.com](http://www.jlg.com)

An Oshkosh Corporation Company