

MANISCOPIC







MRT 2540 PRIVILEGE



- Lift height : 24.60 m
- Max. reach : 18.50 m
- Engine : 150 HP - 110 kw
- 4 wheel drive - 4 wheel steer
- Hydrostatic transmission
- Levelling system

 **MANITOU**

MRT 2540 *PRIVILEGE*

-  **Lift capacity** (on stabilisers)4000 kg
at 500 mm from forks heels
-  **Lift height** :24.60 m
-  **Tyres**
18 - 22,5
-  **Forks** (mm)
Length1200
Width x thickness150 X 50
-  **Multidisc brakes** : hydraulically assisted on both axles
Negative parking brake
-  **Engine Mercedes-Benz**
TypeOM 904 LA (EURO 3)
Capacity4 cyl. 4250 cm³
Power (ISO/TR 14396)150 HP/110 kw
580 Nm of 1200 at 1600 rpm
Water cooling
Direct injection
-  **Transmission**hydrostatic
With automatic power regulation (hydraulic variable displacement pump and motor)
Reversing shiftelectromagnetic
2 speed forward and reverse
Travel speed36 km/h*
*This speed may be limited by local regulations
-  **Rear axle**
Frame levelling on front axle +/- 8° (15%)
Automatic rear axle locking system
over 15° rotation
-  **4 stabilizers**
simultaneous or individually controlled
-  **Total and continuous rotation**
Turret mounted on a double slew ring
Hydraulic and electric rotation
-  **Hydraulics**
3 pumps gear type270 bars/160 l/mn
-  **Control** : 2 electro proportional control joysticks for all hydraulic movements
-  **Capacities**
Cooling system18 l.
Engine oil15 l.
Hydraulic oil200 l.
Fuel tank230 l.
-  **Weight unladen** (with forks)17165 kg
Overall width2.43 m
Overall height3.05 m
Overall length7.82 m
Ground clearance0.37 m
Drawbar pull8200 daN
-  **Standard load moment indicator**
(mobile crane standards)

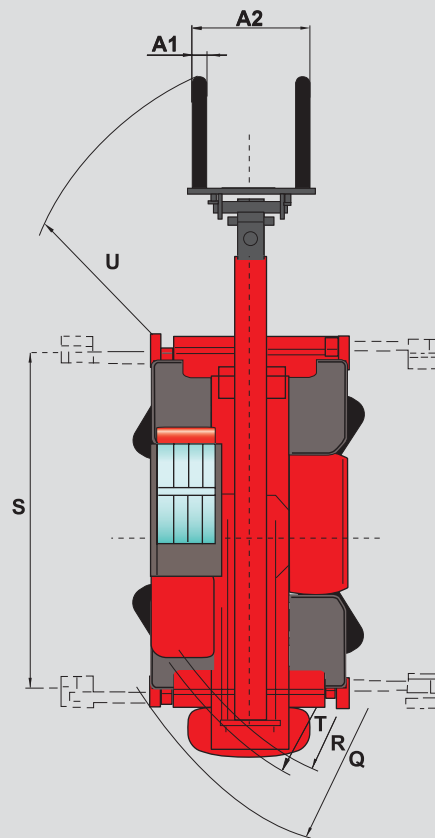
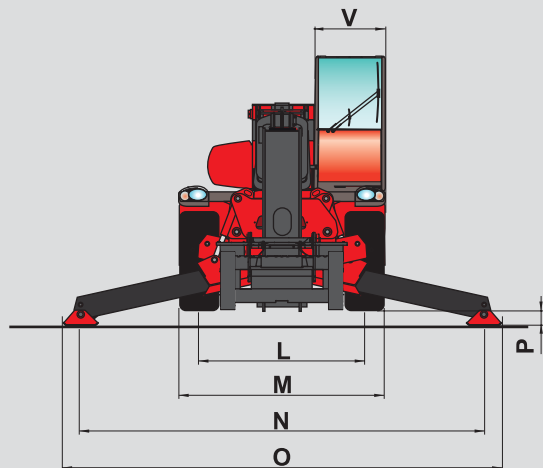
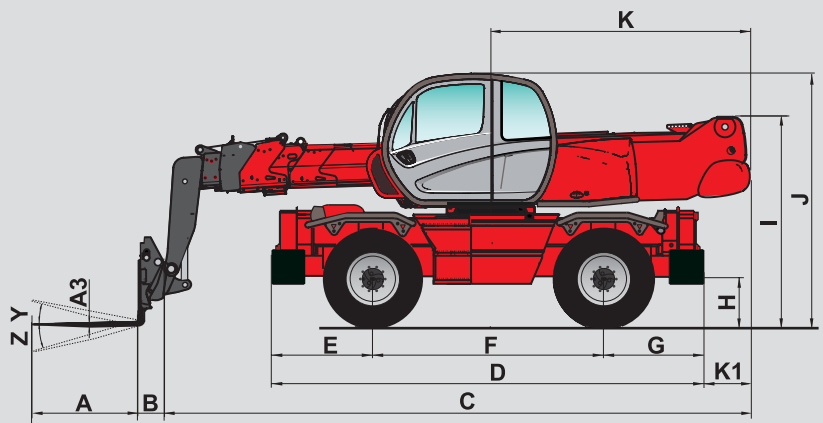

A	1200
A1	150
A2	1320
A3	50
B	290
C	7530
D	5050
E	1155
F	2750
G	1155
H	380
I	2485
J	3050
K	2985
K1	485
L	1930
M	2425
N	4700
O	5100
P	150
Q	4500
R	3800
S	4550
T	4040
U	6700
V	950
Y	12°
Z	105°

mm

This publication in no way constitutes an offer and the company reserves the right to alter specification without prior notice.
The MANITOU models presented in this brochure can be supplied complete with optional equipment attachments.



MANITOU BF SA

B.P. 249 - 44158 Ancenis Cedex - France
Tél. : 33 2 40 09 10 11 / Export Department Fax : 33 2 40 09 10 97
www.manitou.com

700385EN-A - 04/07

